

Ensto Wallbox



Installation Instructions
ENG Operation Instructions



CE

Contents

1. Ensto Wallbox.....	3
2. Safety Instructions.....	3
3. Delivery Contains.....	4
4. Accessories.....	4
5. Mounting instructions.....	9
5.1. Before Installation.....	9
5.2. Wall Mounting with Wall Bracket.....	10
5.3. Ground Mounting on Concrete Casting with Ground Mounting Pole.....	12
5.4. Ground Mounting on Concrete Foundation with Ground Mounting Pole.....	13
5.5. Wall Mounting on Wall Mounting Pole.....	14
5.6. Ground Mounting on Unimi Concrete Foundation.....	14
5.7. Fixing Wallbox on Mounting Poles EVTL43.00 and EVTL48.00.....	16
6. Electrical Connections.....	17
6.1. Wiring Instructions.....	17
6.2. Power Supply.....	18
7. Commissioning.....	20
7.1. Connecting to Wallbox.....	20
8. User Instructions.....	21
8.1. User Interfaces.....	21
8.2. Charging.....	21
9. Technical Information - EVB.....	22
10. Dimension Drawing.....	23
11. Installation / Commissioning Checklist.....	24
12. Maintenance / Preventive Maintenance Instructions.....	25
13. RCD/MCB test instructions.....	25
14. EVB100 Internal Circuit Example.....	26
15. EVB101 Internal Circuit Example.....	27
16. EVB200 Internal Circuit Example.....	28
17. Extension Box EVK.....	30
17.1. Mounting the Extension Box.....	31
17.2. Wiring Instructions.....	32
17.3. Technical Information - EVK.....	34
18. Troubleshooting.....	35
19. Warranty.....	35

1. Ensto Wallbox

EVB100 / EVB103: Single charging unit (3-phase)

EVB200: Dual charging unit (3-phase)

EVB101: Single charging unit (1-phase)

EVB201: Dual charging unit (1-phase)

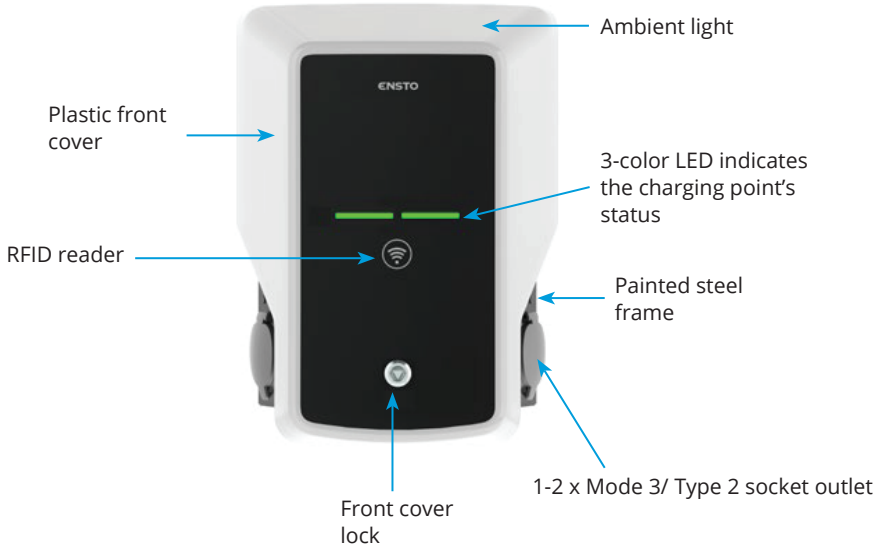

2. Safety Instructions

- *The charging station must be installed by a qualified person.*
- *Read this manual before installation and usage of the charging station.*
- *This manual must be stored in a safe location and be available for future installation and service.*
- *Follow the guidelines in this manual when installing and using the charging station.*
- *The installation must be done according to the local safety regulations, restrictions, dimensioning, rules and standards.*
- *The information provided in this manual in no way exempts the user of responsibility to follow all applicable rules and safety standards.*



3. Delivery Contains

- Charging station
- Installation and Operation instructions

4. Accessories

Flange KOT21715

Included in the delivery.

Note! Cable glands are not included in the delivery.

Please order suitable cable glands separately according to the used supply cable sizes, for example Ensto KTM... cable gland series (polyamide or brass).

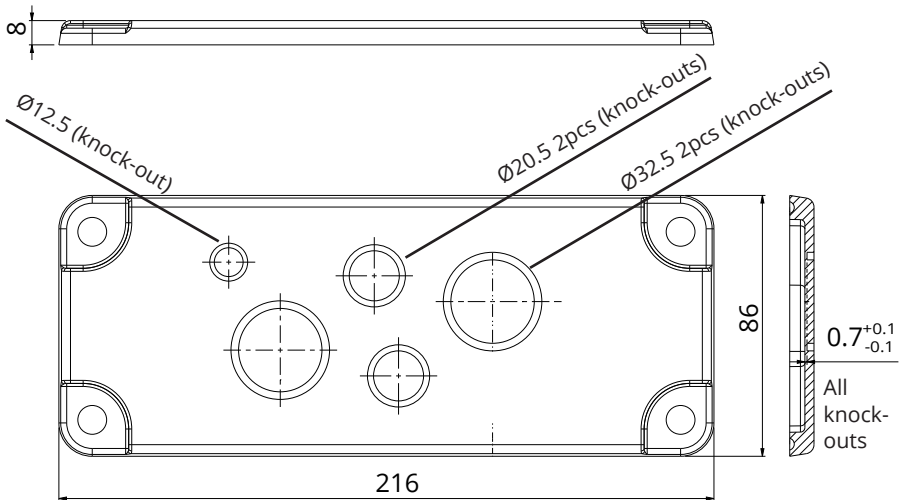

EVTL40.00

Wall bracket

The wall bracket is pre-installed to the charging station.

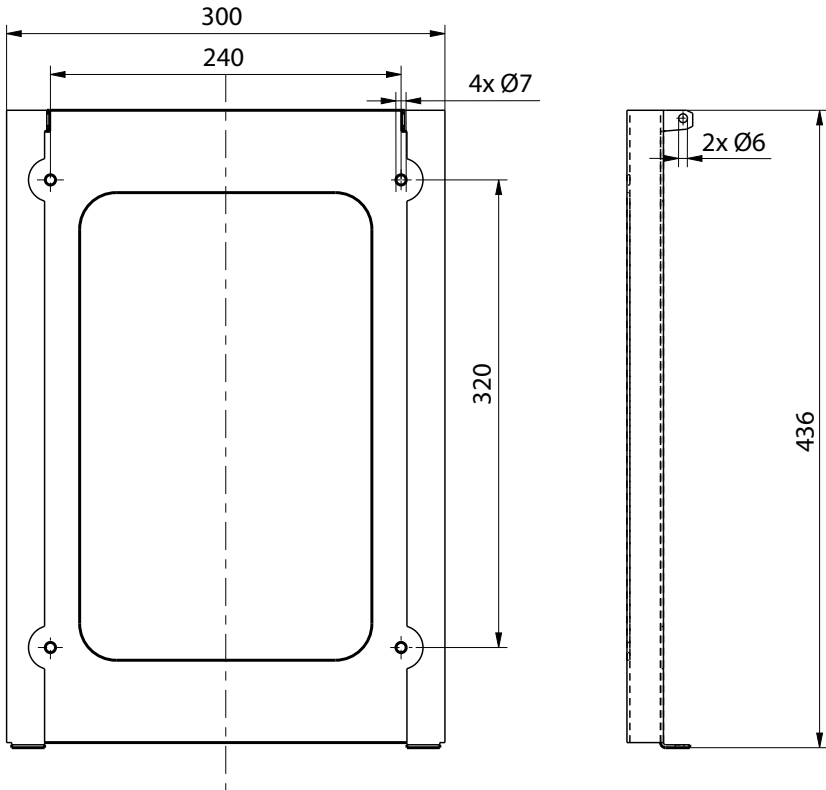

EVTL43.00

Ground / Floor mounting pole

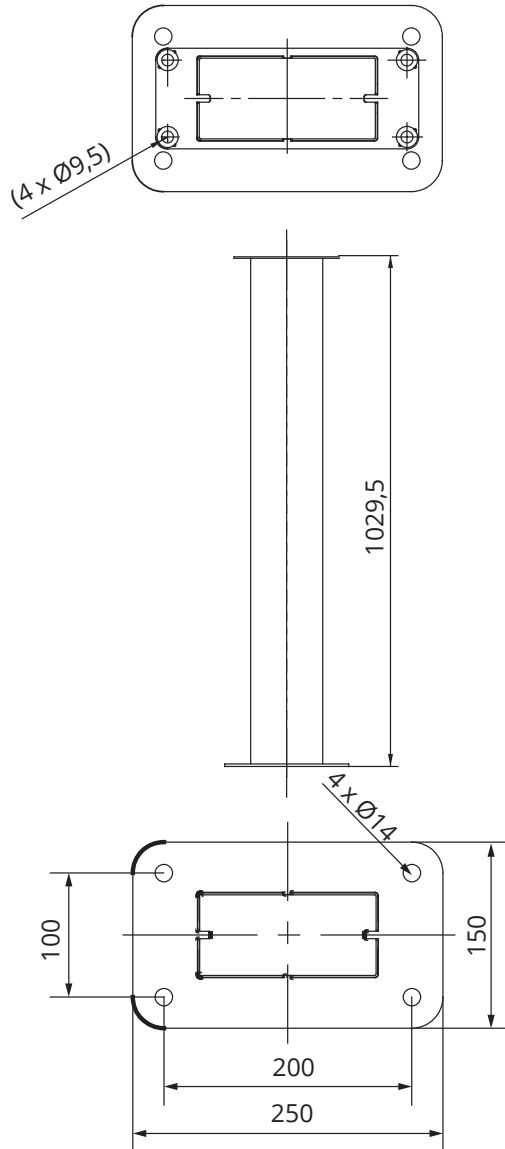

EVTL44.00

Adapter for ground mounting

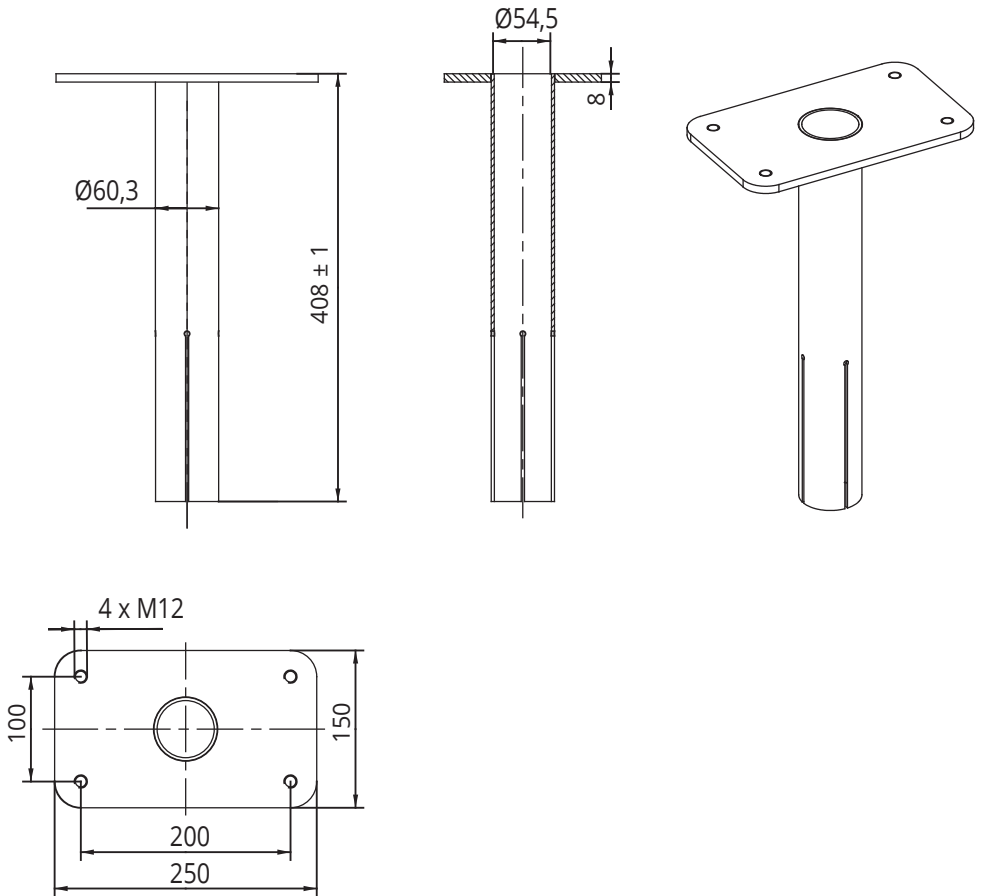

EVTL48.00

Wall mounting pole

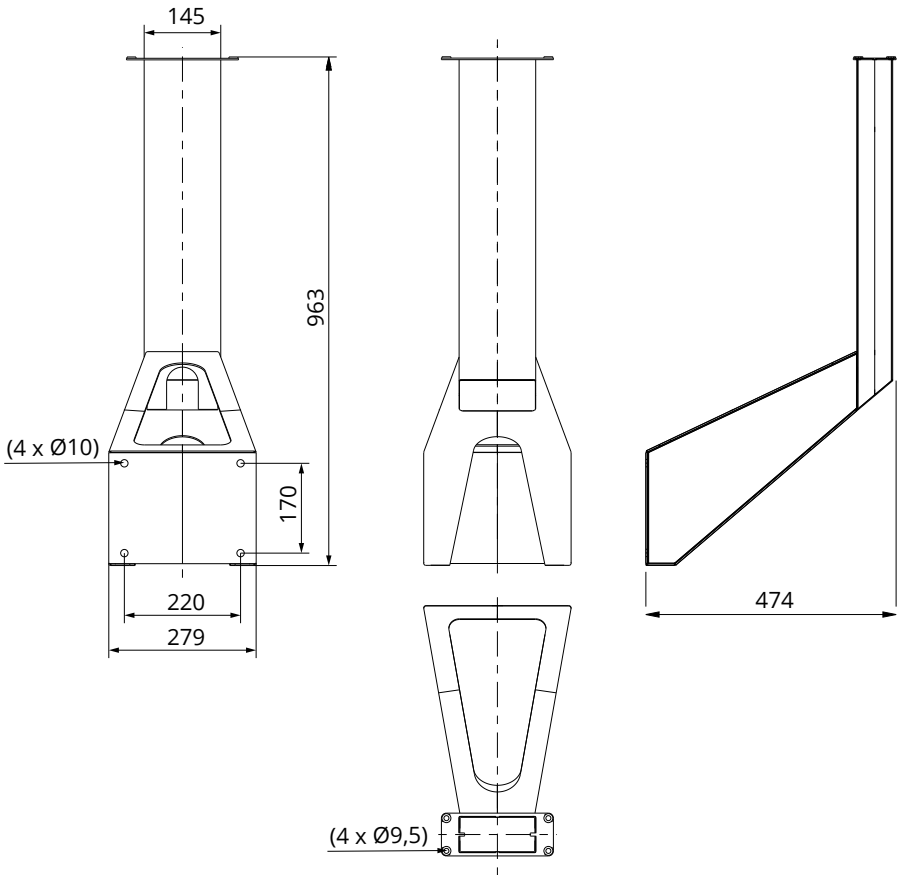

5. Mounting instructions

5.1. Before Installation

Remove the the charging station from its package. Do not scratch the surface of the the charging station after removal from the package.

When selecting installation site, take into account the following:

- The minimum space needed for operating and maintenance.
- Make sure that the mounting foundation is suitable and robust.
- In order to ensure the optimal charging performance, the the charging station should not be exposed to direct sunlight.
- If the charging station is installed in conditions where there is a risk of metal rusting, visible metal surfaces must be protected with anti-corrosion agent.



5.2. Wall Mounting with Wall Bracket

Items needed: Wall bracket EVTL40.00 1 pcs
 Screws 4 pcs

Installation steps

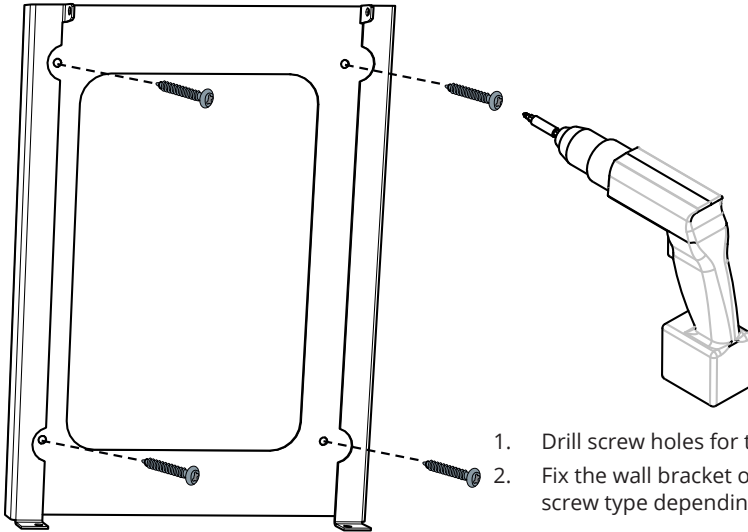

1. Drill screw holes for the wall bracket.
2. Fix the wall bracket on the wall. Use screw type depending on the wall type.

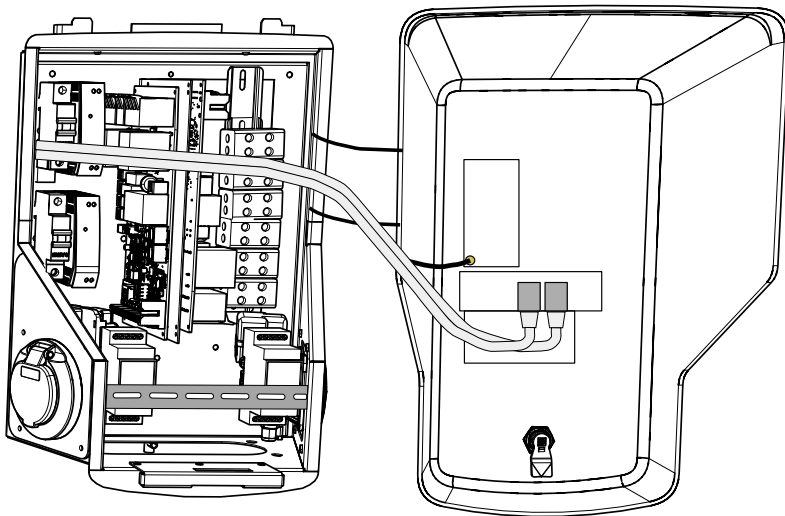

3. Open the front cover lock and remove the front cover.

Note! RFID, LED module and antenna cables are attached to the front cover. Be careful not to break any components when you remove the front cover.

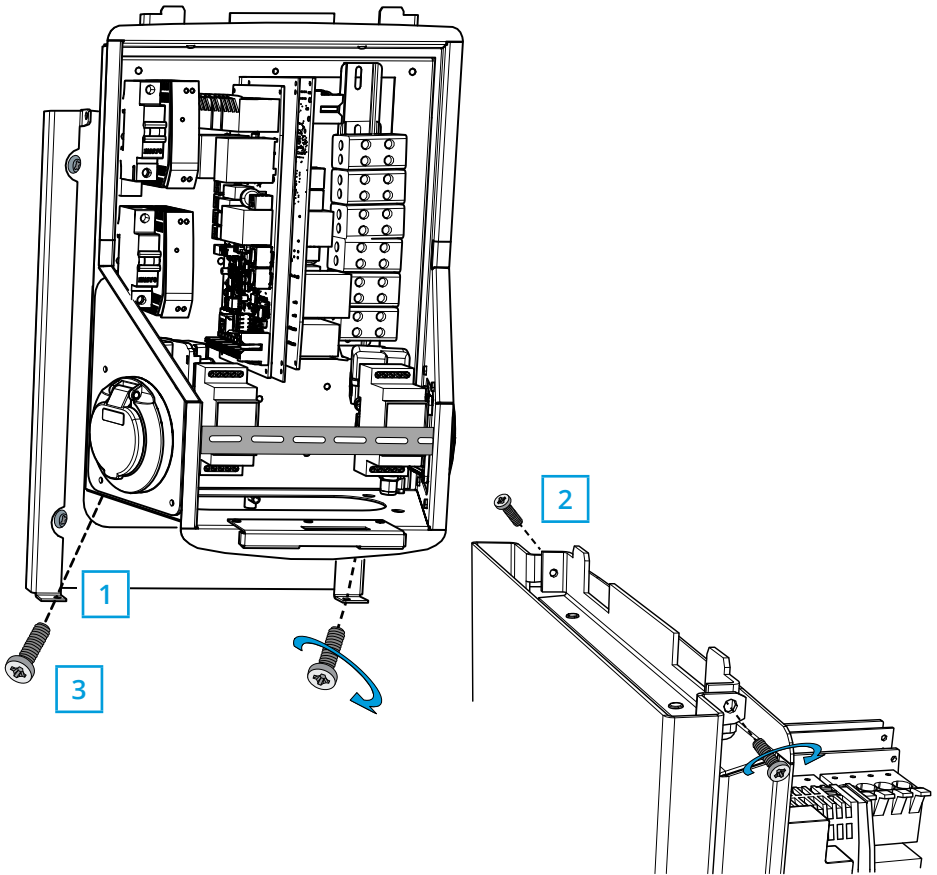

4. Place the Wallbox on the wall bracket (1).
5. Attach the top of the Wallbox on the wall bracket using the screws included in the delivery (2).
6. Secure the bottom of the Wallbox with the screws included in the delivery (3).

5.3. Ground Mounting on Concrete Casting with Ground Mounting Pole

Items needed:	Ground mounting pole EVTL43.00	1 pcs
	Anchor bolts M12	4 pcs
	Washers (not included)	
	Nuts (not included)	

Make sure that the materials used for the concrete casting and the installation procedures follow local building regulations and safety standards.

- Dig a pit for the concrete casting. The pit floor should be trampled and horizontal.
- Put cable and possible drain pipes in place.
- Fill the pit with concrete.
- Let the concrete solidify, make sure that the surface stays solid and level during the process.

Installation steps

1. **Make sure that the concrete surface is flat and level.**
2. Drill a hole in the concrete for the anchor bolts. For more information, please see the anchor bolt instructions.
3. Put anchor bolts in place.

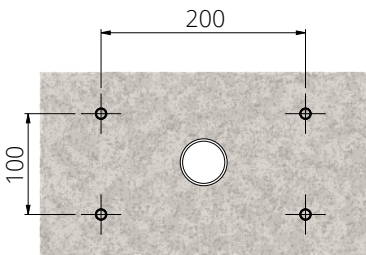
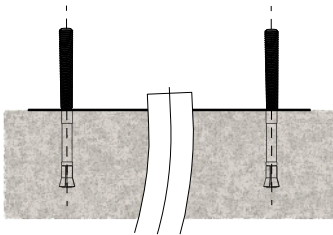

4. Pull the electric cables approx. 1500 mm measured from the concrete surface.
5. Fix the ground mounting pole on the anchor bolts with washers and nuts.
6. Pull the electrical cables through the ground mounting pole.
7. Attach the Wallbox on the mounting pole. See instructions on page 16.

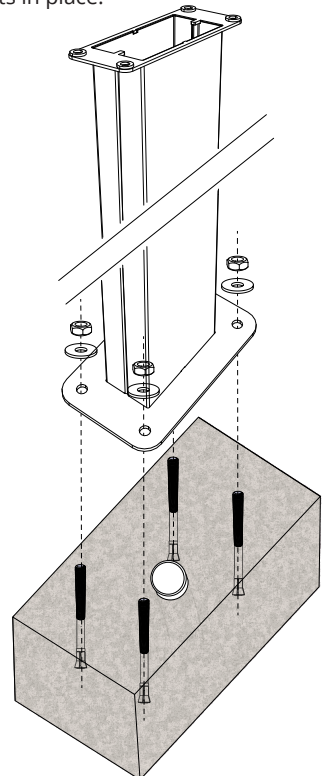

5.4. Ground Mounting on Concrete Foundation with Ground Mounting Pole

Items needed:	Ground mounting pole EVTL43.00	1 pcs
	Adapter for ground mounting EVTL44.00	1 pcs
	Concrete foundation (from different manufacturers)	1 pcs
	Bolts (not included)	
	Washers (not included)	
	Nuts (not included)	

Installation steps

1. Dig holes for cable conduits and the concrete foundation to necessary depths.
2. Add gravel to the bottom of the trench, to such thickness that the top of the foundation will reach desired level when lifted into the hole. Note! Consider the possible paving materials when setting the level.
3. Lift the concrete foundation into the installation hole. For more information, please see the concrete foundation mounting instructions.
4. Put cable and possible drain conduits in place.
5. Lift the adapter EVTL44.00 into the concrete foundation. Cut the adapter, if necessary. Adjust the adapter in such a manner, that the adapter is perpendicular. Make sure, that the adapter is securely in place and does not swing.
6. Pull electric cables through the conduits and the adapter approx. 1500 mm measured from the adapter flange.
7. Tighten the foundation to its place by filling the excess space outside the foundation with gravel.
8. Fix the ground mounting pole on the adapter with bolts, washers and nuts.
9. Pull the electrical cables through the ground mounting pole.
10. Attach the Wallbox on the mounting pole. See instructions on page 16.

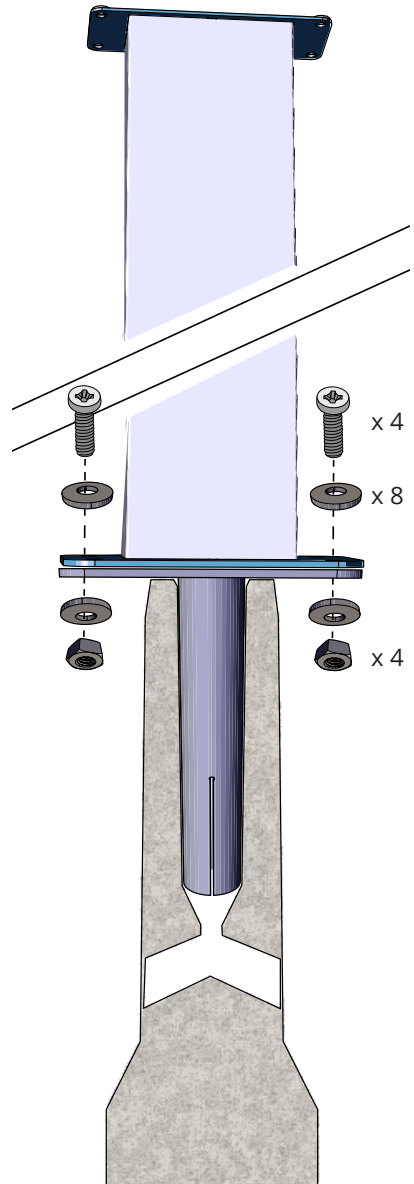

5.5. Wall Mounting on Wall Mounting Pole

Items needed: Wall mounting pole EVTL48.00 1 pcs
Bolts, washers and nuts / screws (not included)

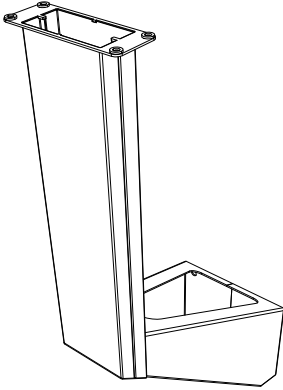

Installation steps

1. Pull the electrical cables approx. 2000 mm measured from the wall.
1. Drill screw holes for the wall mounting pole.
2. Fix the wall mounting pole on the wall. Use fastening accessories depending on the wall material.
3. Pull the electrical cables through the wall mounting pole.
4. Attach the Wallbox on the wall mounting pole. See instructions on page 16.

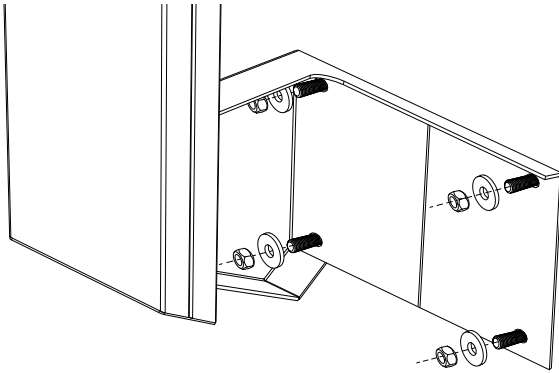

5.6. Ground Mounting on Unimi Concrete Foundation

This installation example describes the installation procedure using a concrete foundation supplied by Unimi - Solutions.

Items needed:

Ground mounting pole EVTL43.00 1 pcs (1 x EVB) /
2 pcs (2 x EVB)

Please order the following items from www.unimi.se

Concrete foundation	1 pcs
Cover plate	1 pcs
Adapter for 1 x EVB, product code US7650	1 pcs
Adapter for 2 x EVB, product code US27657	1 pcs

Note! When using the adapter for two Wallboxes (US27657), you can get up to four charging outlets.

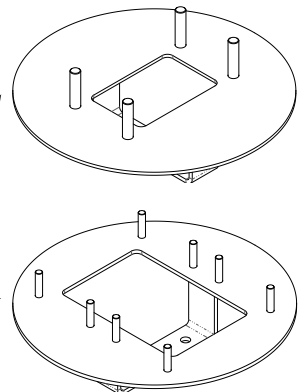

Installation steps

1. Dig holes for cable conduits and the concrete foundation to necessary depths.
2. Adjust the depth of the hole so that the top of the foundation will be in level with the surrounding ground surface. Note! Consider the possible paving materials when setting the level.
3. Cover the unused conduit openings with plugs, which are included in the foundation delivery.
4. Lift the foundation into the installation hole, the attachment bar embedded in the foundation can be used as a lifting point. The attachment bar should be oriented to allow attachment of the Wallbox into desired position.
5. Lay the cable conduits into the trenches and install conduits to relevant inlets.
6. Pull electric cables through the conduits into the foundation approx. 1500mm measured from the top of the foundation.
7. Tighten the foundation to its place by filling the excess space outside the foundation with gravel.
8. Set the final layer of gravel so that the top of the foundation will be in level with ground or the final paving material.
9. Always place a cover plate on the foundation, if the Wallbox is installed in a separate session than the foundation.
10. When you start the installation of the Wallbox, remove the cover plate.
11. Put the adapter element on the foundation.
12. Attach the adapter on the foundation attachment bar with bolts included in the delivery.
13. Fit the mounting pole to the threaded bolts on the adapter. Secure with the nuts included in the delivery.
14. Pull the electrical cables through the mounting pole.
15. Attach the Wallbox on the mounting pole. See instructions on page 16.

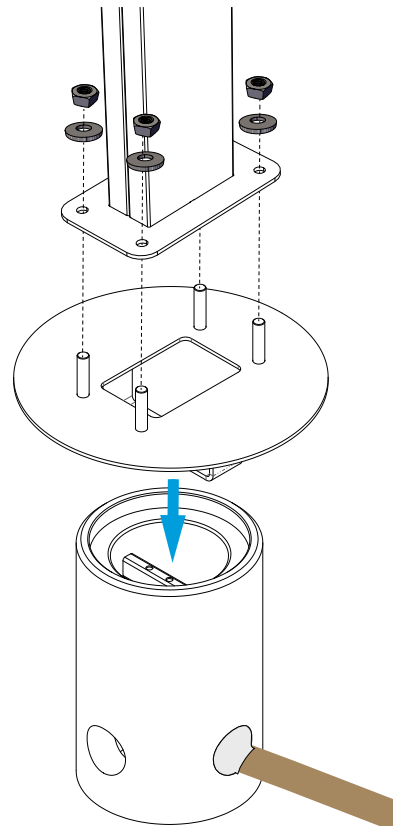
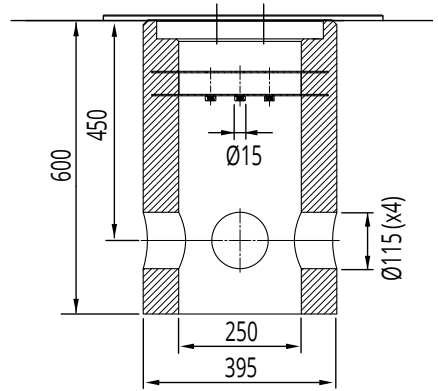

5.7. Fixing Wallbox on Mounting Poles EVTL43.00 and EVTL48.00

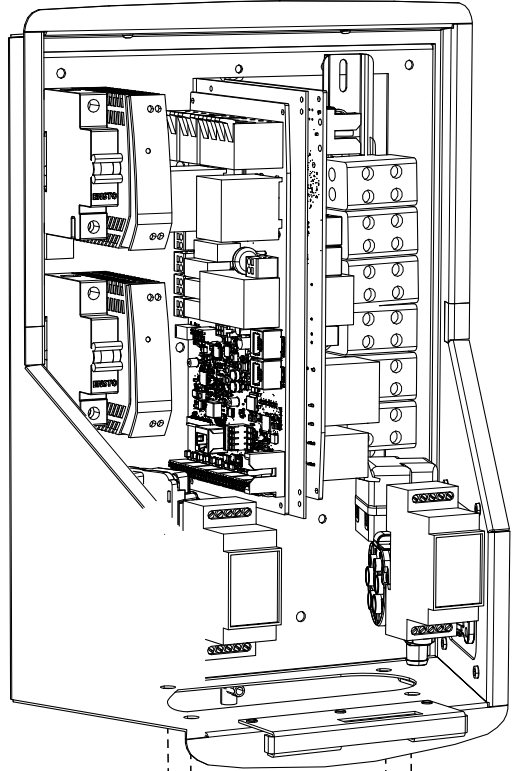

Installation steps

1. Open the front cover lock and remove the front cover.
Note! RFID, LED module and antenna cables are attached to the front cover. Be careful not to break any components when you remove the front cover.
2. Remove the flange at the bottom of the Wallbox frame.
3. Open the knock-outs and insert the cable glands needed for electrical cables on flange KOT21715.
4. Pull the electrical cables through the cable glands.
5. Fix the Wallbox and flange KOT21715 on the mounting pole using the screws included in the delivery.

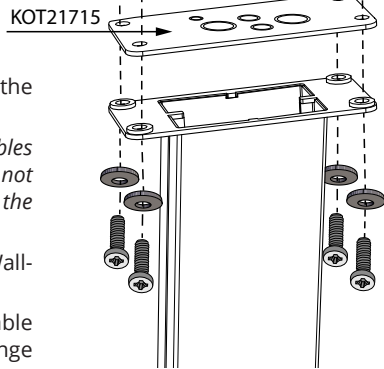

6. Electrical Connections

6.1. Wiring Instructions

1. Remove the front DIN rail if needed to make more space for the installation work.
2. Pull the supply cable through the cable gland approx. 600 mm measured from the cable gland exit.
3. Remove the cable sheath approx. 200 mm.
4. Secure the front DIN rail in place.
5. Pull the supply cable through the plastic guide included in the delivery.
6. Run the supply wiring above the DIN rail in such a manner that the socket outlet locking system is not damaging the supply wires.
7. Cut the supply cable leads in different lengths. Leave the ground lead long enough so that if a fault occurs it is the last one that comes loose.
8. Strip the leads 25 mm and connect to the supply connectors.
9. Ensure that the RFID, LED module and antenna cables are routed correctly.
10. Close the front cover.

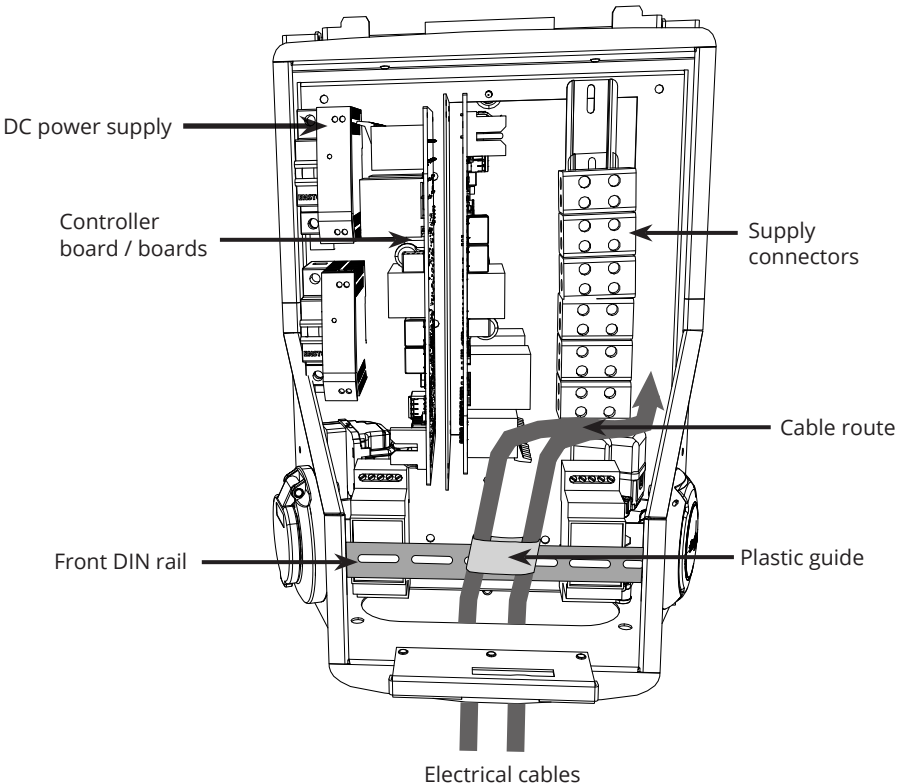

6.2. Power Supply

The voltage and current ratings including cables and line protector dimensioning must comply with national regulations. System dimensioning must be done by a qualified electrical designer.

Connect separate supply cables for each charging outlet.

Stranded cables are recommended in Wallbox installations.

EVB100 and EVB200: A Residual current protection device (RCD) and a circuit breaker (MCB) for each charging outlet must be installed in the switchboard.

EVB101/ EVB103 / EVB201 / EVB203:

A combined RCD / MCB is integrated in the charging station.

Example 1: Supply connection from TN network for Wallbox with 2 outlets

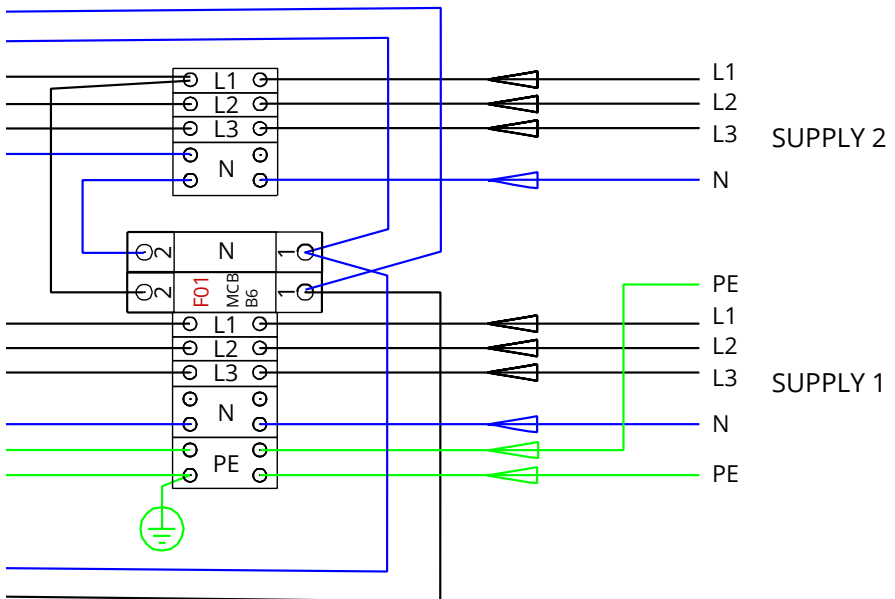

Example 2: Supply connection from IT network for Wallbox with 2 outlets

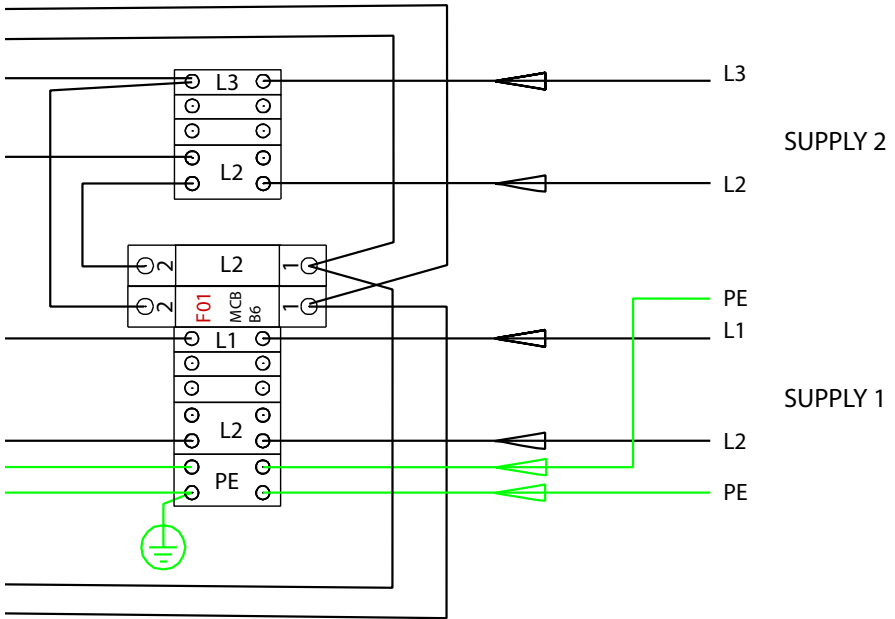

Example 3: Supply connection for Wallbox with 1 outlet, integrated RCD / MCB

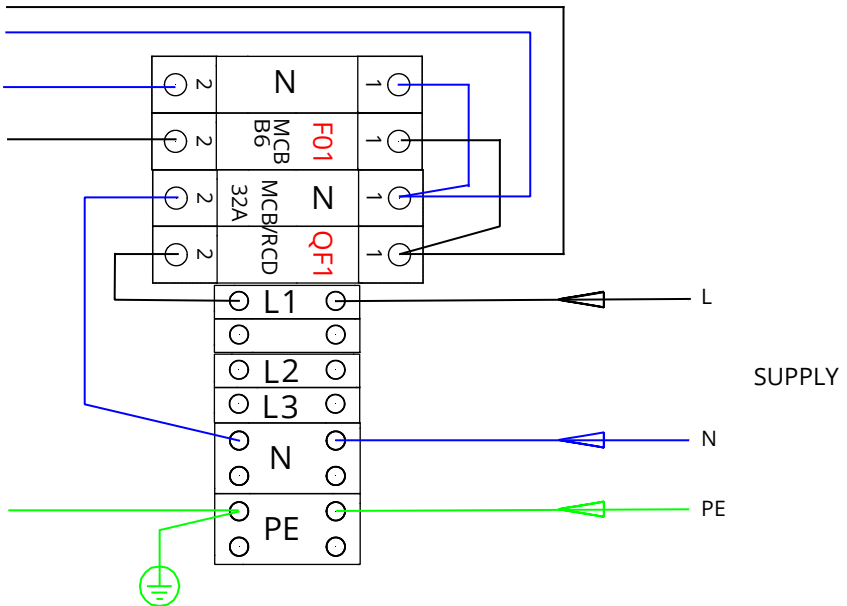

7. Commissioning

Before commissioning the Wallbox must be installed according to the installation instructions.

By default all Wallboxes are operating in free charging mode (standalone operation). In this free charging mode external communication (Ethernet, 2G/3G/4G) is not active. If the Wallbox is going to be connected to some back-office (online mode), first make sure that the basic functionality is working before establishing communication.

7.1. Connecting to Wallbox

If you want to change the default settings, you must connect to Wallbox via web configuration tool to be able to proceed with the commissioning settings. Use Firefox or Windows Explorer web-browser for configuring.

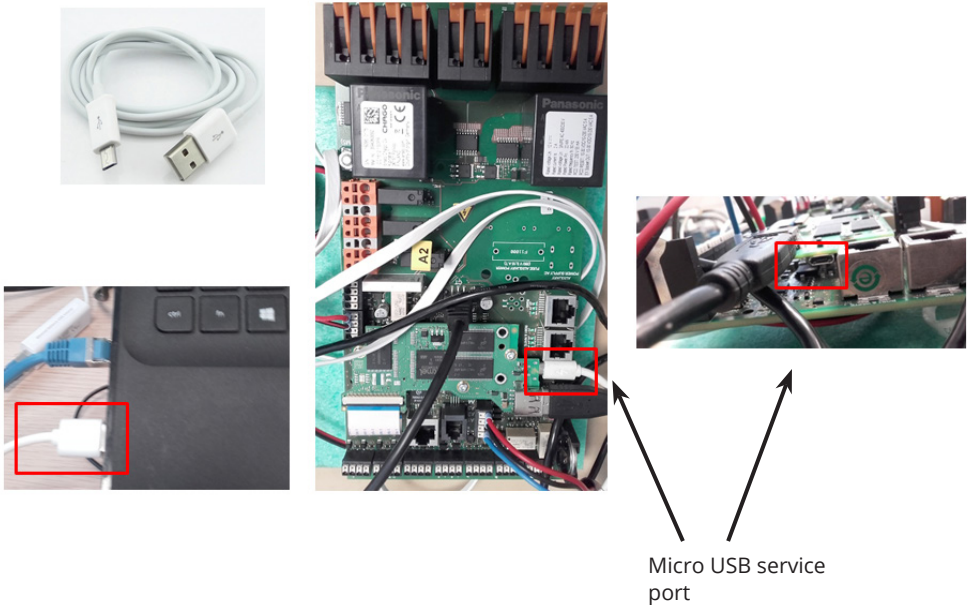

Please see detailed commissioning instructions on <https://evwiki.ensto.technology/>

8. User Instructions

8.1. User Interfaces

LED signal lights will show the status of the charging point as described below:

Charging point status	LED light	LED operation
Charging point is free and ready to use	Green	Stable
RFID read, user login ongoing	Green	Flashing
User login fail, access denied	Red	Stable
User login passed, charging allowed	Green	Waving
While connecting the cable	Green	Flashing twice
Vehicle connected, charging not started	Green	Waving
Vehicle connected, starts charging	Blue	Waving
Charging ongoing	Blue	Stable
Error state	Red	Stable

8.2. Charging

Free charging

- Plug in your electric vehicle to start charging.
- Unplug your electric vehicle to stop charging.

Charging with RFID

You must have an RFID tag which has a permission to access the charging station.

Start Charging with RFID

- When the charging point is free and the indicator light shows green, you can start a charging event.
- Show the RFID tag to the RFID reading area.
- When the RFID tag is read, the charging point will flash green and verify the user permission to charge. If the user login is failed, the indicator light turns to red. If the user login is passed, the indicator light turns to waving green.
- Now you are logged in to the charging point.
- Plug in the electric vehicle for charging. The indicator light turns to stable blue.

Stop Charging with RFID

- Show the RFID tag to the RFID reading area.
- When you stop the charging event, the indicator light turns to waving green and you are able to unplug the charging cable.
- After you have unplugged, you are logged out from the charging point and the charging point is free for the next user.

9. Technical Information - EVB

Electrical Connections	
Nominal supply voltage	1-ph/3-ph, 230/400VAC, 50Hz
Charging current (nominal)	3x32A / 1x32A, configurable between 6A...32A
Charging power (nominal)	Max. 22kW per charging outlet
Supply connections and terminals	L1, L2, L3, N, PE Cu 2.5–50 mm ² Recommended 10 mm ² at nominal power Tightening torque Nm: 4 Nm (2.5 - 4 mm ²), 12 Nm (6 - 50 mm ²)

Design and Mechanics	
Materials	Frame: Painted steel frame Cover: Plastic
Color	Frame: RAL7021 "Anthracite" Cover: White and black tape
Weight	approx. 10 kg, depends on product configuration
Enclosure class	IP54
Shock protection rate	IK10
Operating temperature	-30 °C ... +50 °C
Standard	IEC 61851-1
Approvals / markings	CE

User Interface	
Socket outlet	Mode 3 / Type 2
Charging status indication	3-color LED <ul style="list-style-type: none"> • Green / Ready • Blue / Charging • Red / Error)
Use access	RFID (ISO/IEC 14443A, ISO/IEC 15693) Free access Mobile apps via 3rd party operators
Current measurement	Integrated / on-board measurement

Safety Features	
RCMB	On-board: RCMB (6mA DC residual current detection)
RCD	EVB100 / EVB200: To be located in distribution board (at least type A, 30mA)
MCB	EVB100 / EVB200: To be located in distribution board (class C, nominal current 32A)
RCB / MCB	EVB101 / EVB201 / EVB103: integrated, type A 30mA, class C, nominal current 32A
Control voltage	12VDC
Temperature control	High operating temperature, such as direct sunlight, can cause reduced charging current or temporary interruption in the charging procedure

Control and Communication	
Operation mode	Standalone / Online
Wireless	2G / 3G / 4G
Wired	Ethernet
Protocol	OCPP1.5 or OCPP1.6

10. Dimension Drawing

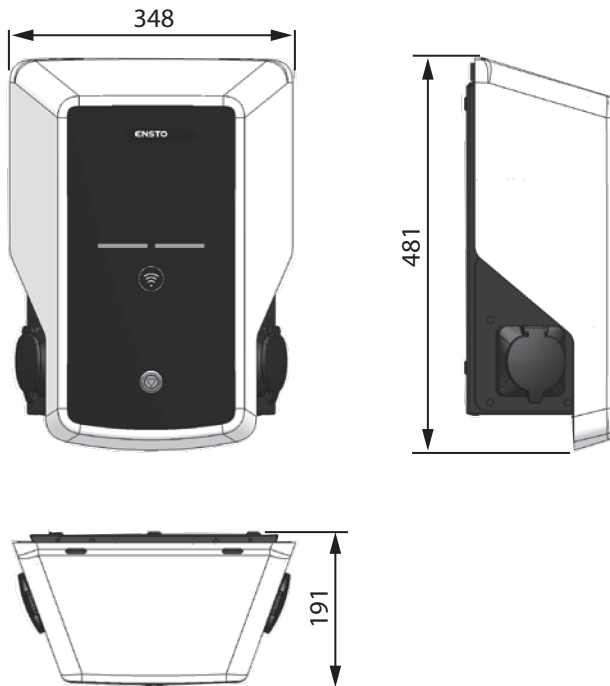

11. Installation / Commissioning Checklist

Introduction

This checklist is a guidance for ensuring both mechanical and electrical installation as well as commissioning of the Wallbox.

Checking the Installation



Go through the visual, mechanical and electrical installation when the charging station is un-powered.

CATEGORY	X	ITEM
Overall look		Ordered material has been received.
		Protective plastic wrapping have been removed.
		No scratches or damages may be seen.
Mechanical installation		Charging station is fixed properly on installation site.
Electrical installation		Charging station's power supply capacity meets electrical planning (cable size, MCB...). Review local electrical design plan.
		Gently push the charging station with a hand to create vibration to ensure no bad contact / connection exist (wire or PCB).
		Check the tightness of the PE-cable screw.
		Power supply cables (L1, L2, L3, N and PE) are properly connected.
		Insulation of power supply cables is intact (L1, L2, L3, N and PE)
		Voltage between PE and N is less than 10 V
Operational check		PE conductor resistance is less than 3 Ω
		All the LED states / colors (green, blue, red) and the RFID reader are functioning. Create fail and charge with a RFID tag. Red at bootup, green at idle and blue while charging.
		Available electricity at the sockets. All the contacts (L1, L2, L3) must be tested. Use a Mode 3 tester.
		Verify that when the charging station LED is green, there is no power at the socket contact (L1, L2, L3, N).
		Test the functioning of Mode 3 (from green to blue). Use a Mode 3 tester.
Ready for use		Test the function of the RCD / MCB. Depending on the charging station model, the device is integrated in the charging station or installed in the switchboard.
		Correct SW in use
		Correct operating mode <ul style="list-style-type: none"> • Standalone • Online

12. Maintenance / Preventive Maintenance Instructions

1 x per year



WARNING! *Danger of electrical shock or injury.
Disconnect power before working inside the device or removing any components.*

X	MAINTENANCE ACTION
	Retighten all the screws on electric components.
	Check the Mode 3 socket for burn or damaged parts and if needed, change it (socket cost is not under warranty).
	Check the charging cable and if needed change it.
	Check the sealings.
	Gently push the charging station with a hand to create vibration to ensure no bad contact / connection exist (wire or PCB).
	All the LED states / colors (green, blue, red) and the RFID reader are functioning. Create fail and charge with a RFID tag. Red at bootup, green at idle and blue while charging.
	Available electricity at the sockets. All the contacts (L1, L2, L3) must be tested. Use a Mode 3 tester.
	Test the functioning of Mode 3 (from green to blue). Use a Mode 3 tester.
	Check tightness of the PE-cable screw.
	Test that the voltage between PE and N is less than 10 V.
	Test that the PE conductor resistance is less than 3 Ω.
	Test the surge arrester, if there is any.
	SW update if needed (if in service contract).
	Restart the charging station from F0, ensure it will restart properly.
	Check the visible metal parts for rust. Apply anti-corrosion agent, if needed.
	Test the function of the RCD / MCB every six months. Depending on the charging station model, the device is integrated in the charging station or installed in the switchboard.

13. RCD/MCB test instructions

- Press the **TEST** button.
- The rocker turns to **0** position.
- Turn the rocker back to **I** position.
- If a fault occurs, contact an electrician.

14. EVB100 Internal Circuit Example

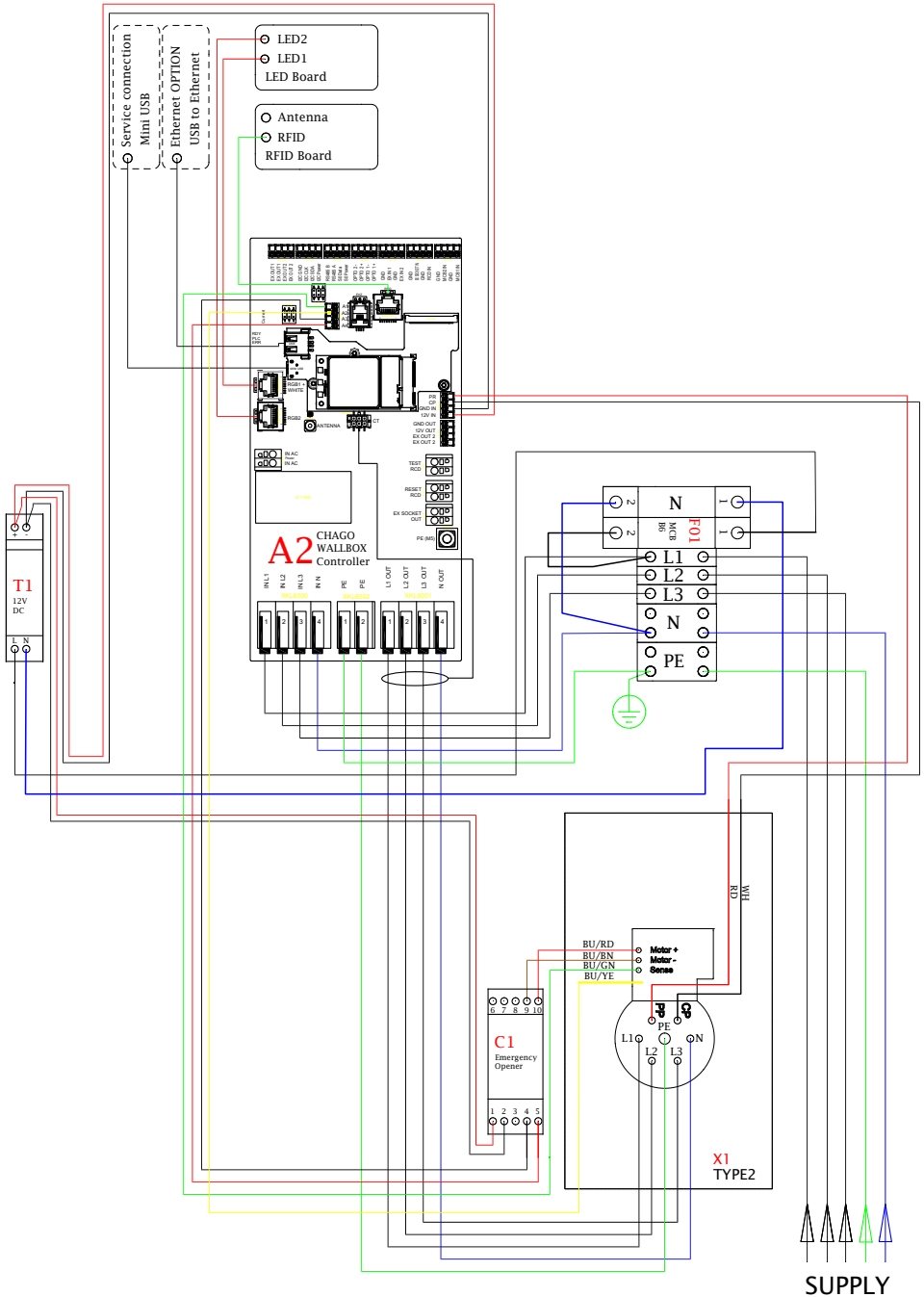

15. EVB101 Internal Circuit Example

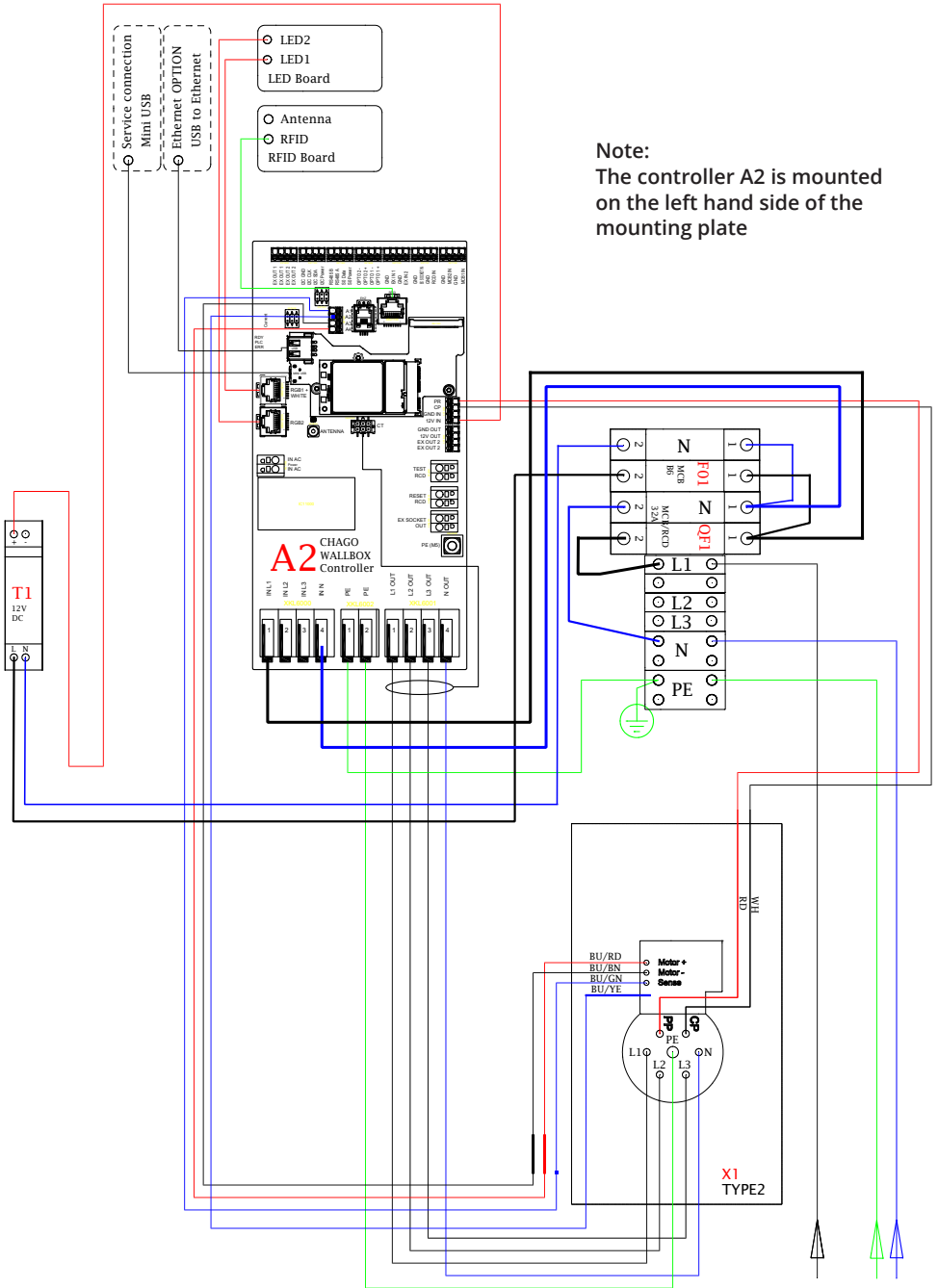

Note:
The controller A2 is mounted on the left hand side of the mounting plate

16. EVB200 Internal Circuit Example

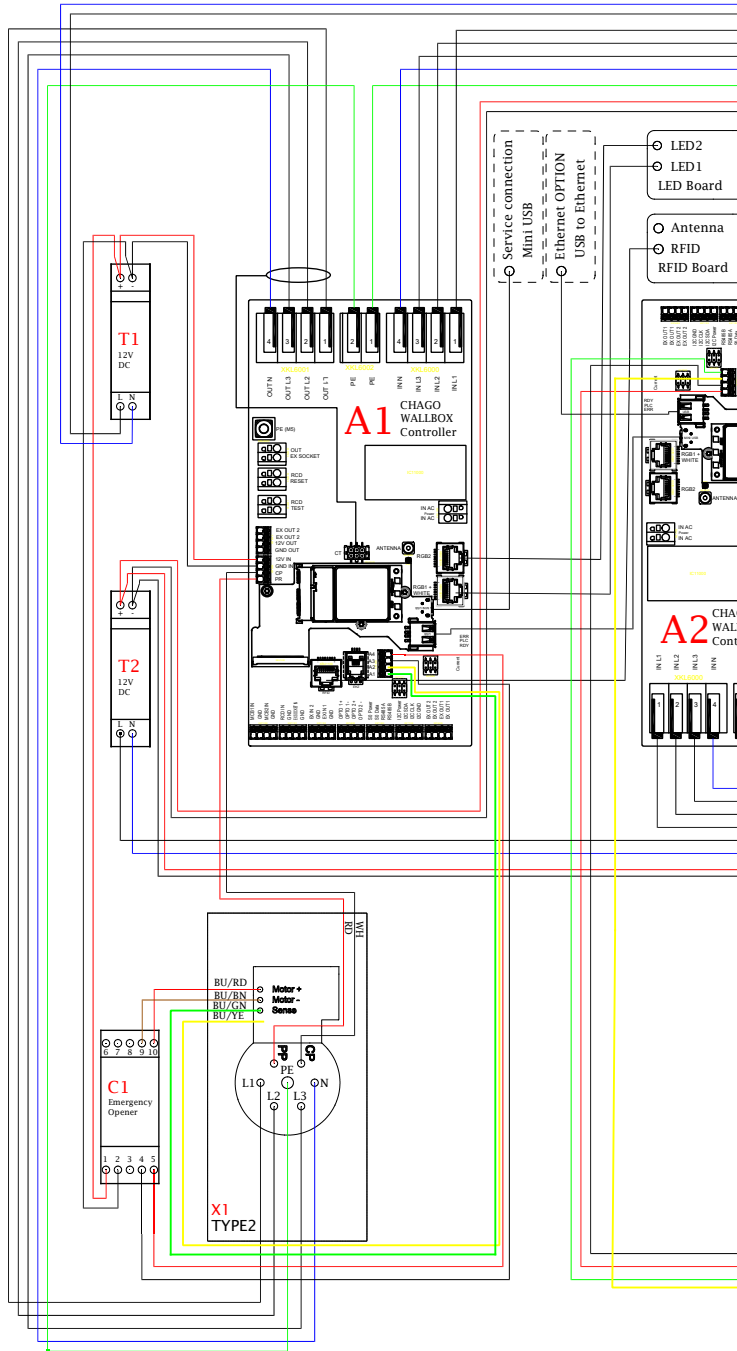

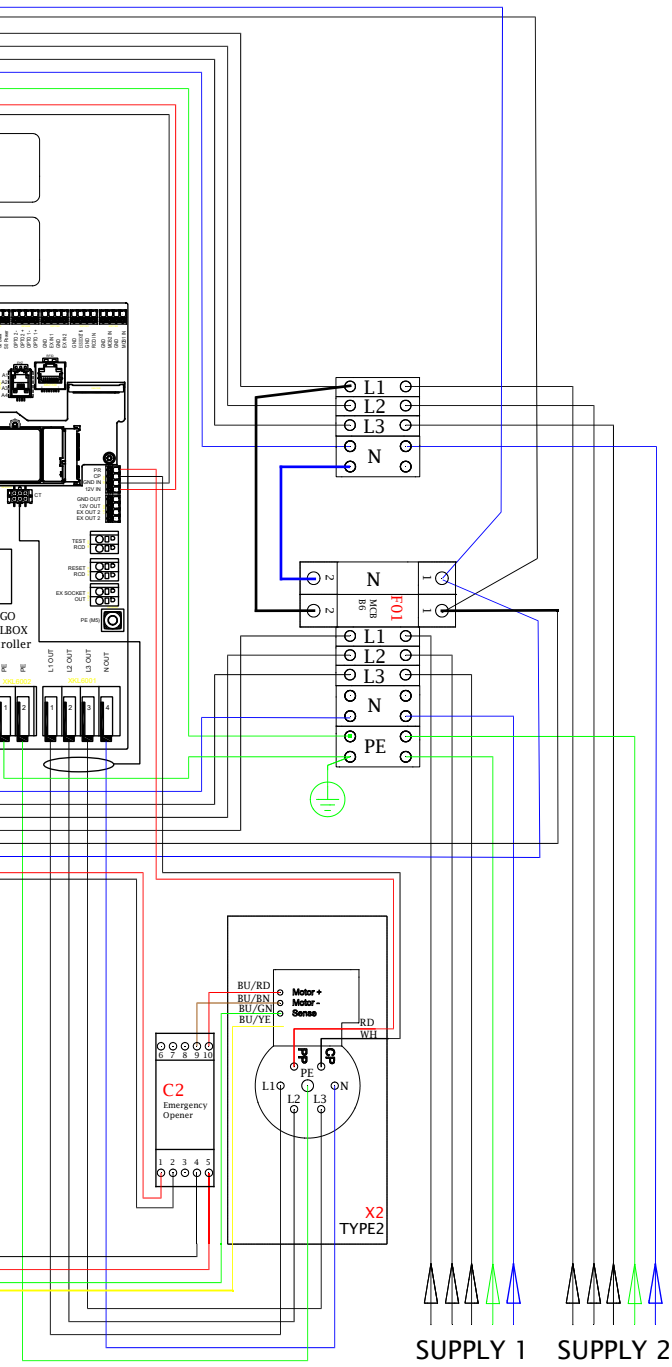

17. Extension Box EVK...

The EVK... is designed as an extension box for EVB100 and EVB200. As default the extension box is provided with RCB/MCB (combined residual current protection device and a circuit breaker) and a MID class energy meter.

Note! Cable glands are not included in the delivery.

Please order suitable cable glands separately according to the used cable sizes, for example Ensto KTM... cable gland series (polyamide or brass).

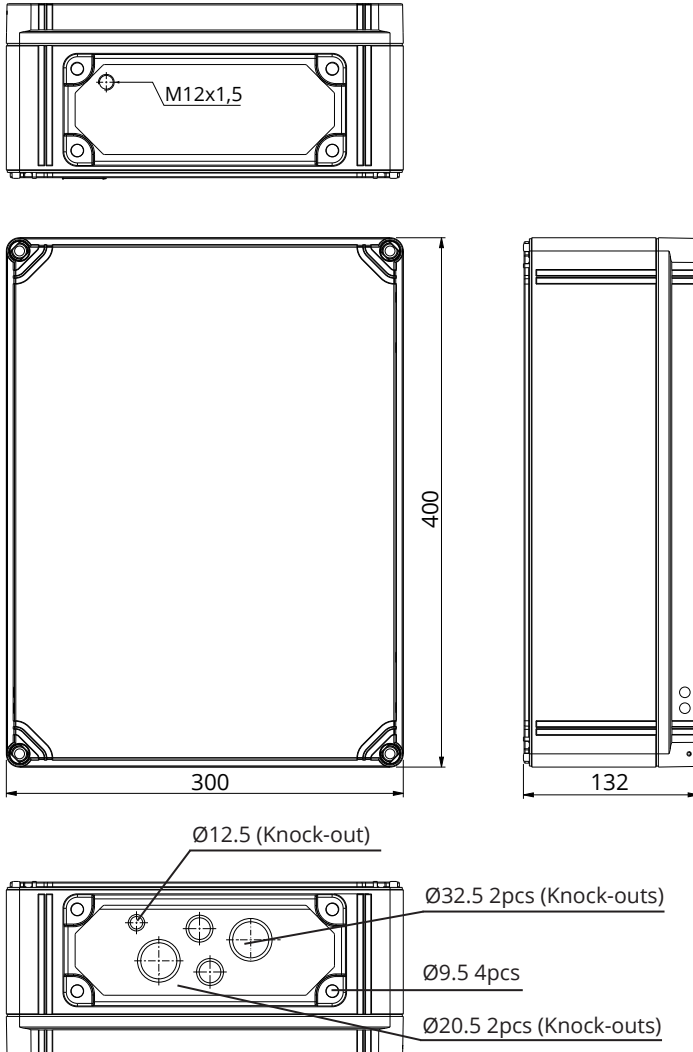

17.1. Mounting the Extension Box

Mount the extension box as near to the Wallbox as possible to minimize the length of the connection cables.

Items needed: Extension box EVK... 1 pcs
 Fastening set including mounting lugs and screws
 Screws (not included)

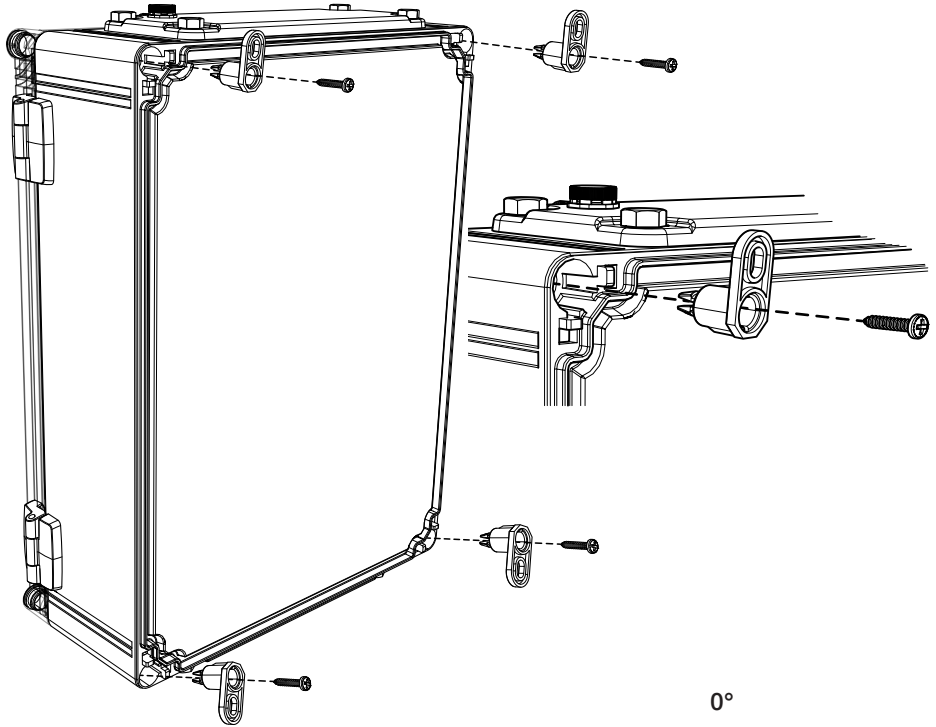

Installation steps

1. Put the fastening lugs in place on the rear side of the enclosure.
2. Secure the lugs with the screws included.
3. You can put the fastening lugs in three possible positions.
4. Prepare the wall for installation. Use screw type depending on the wall type.

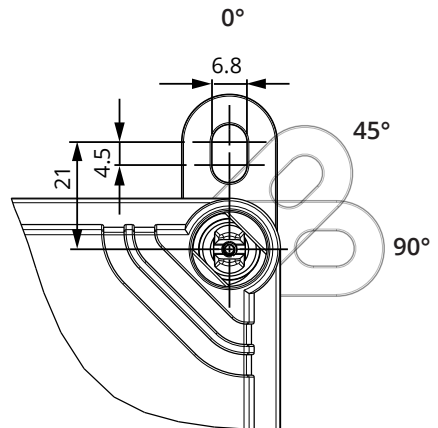

17.2. Wiring Instructions

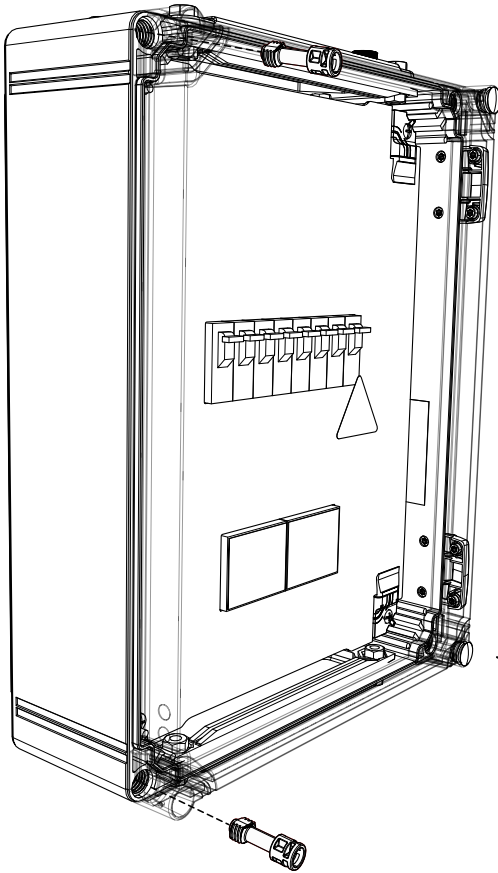

1. Open the transparent cover by removing the cover screws (2 pcs).

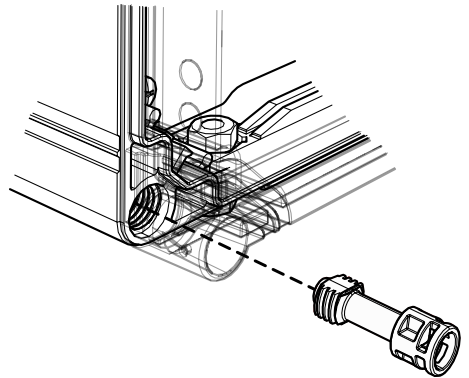

2. Bring the supply cable through the top flange of the enclosure.
3. Connect the supply cable leads to the supply terminals on the extension box.
4. Remove the flange at the bottom of the extension box.
5. Open the knock-outs and insert the cable glands needed for connection cables.
6. Cut the connection cables in suitable lengths. Make sure that the supply connection cable is long enough so that the ground lead reaches the PE terminal on the extension box.
7. Connect the extension box to the Wallbox, see wiring example on page 33.
8. See also Wallbox wiring instructions on page 17.

Example: Connection of EVK... extension box and Wallbox with 2 outlets



WARNING! Danger of electrical shock or injury.
 Always disconnect power before carrying out work on the device.

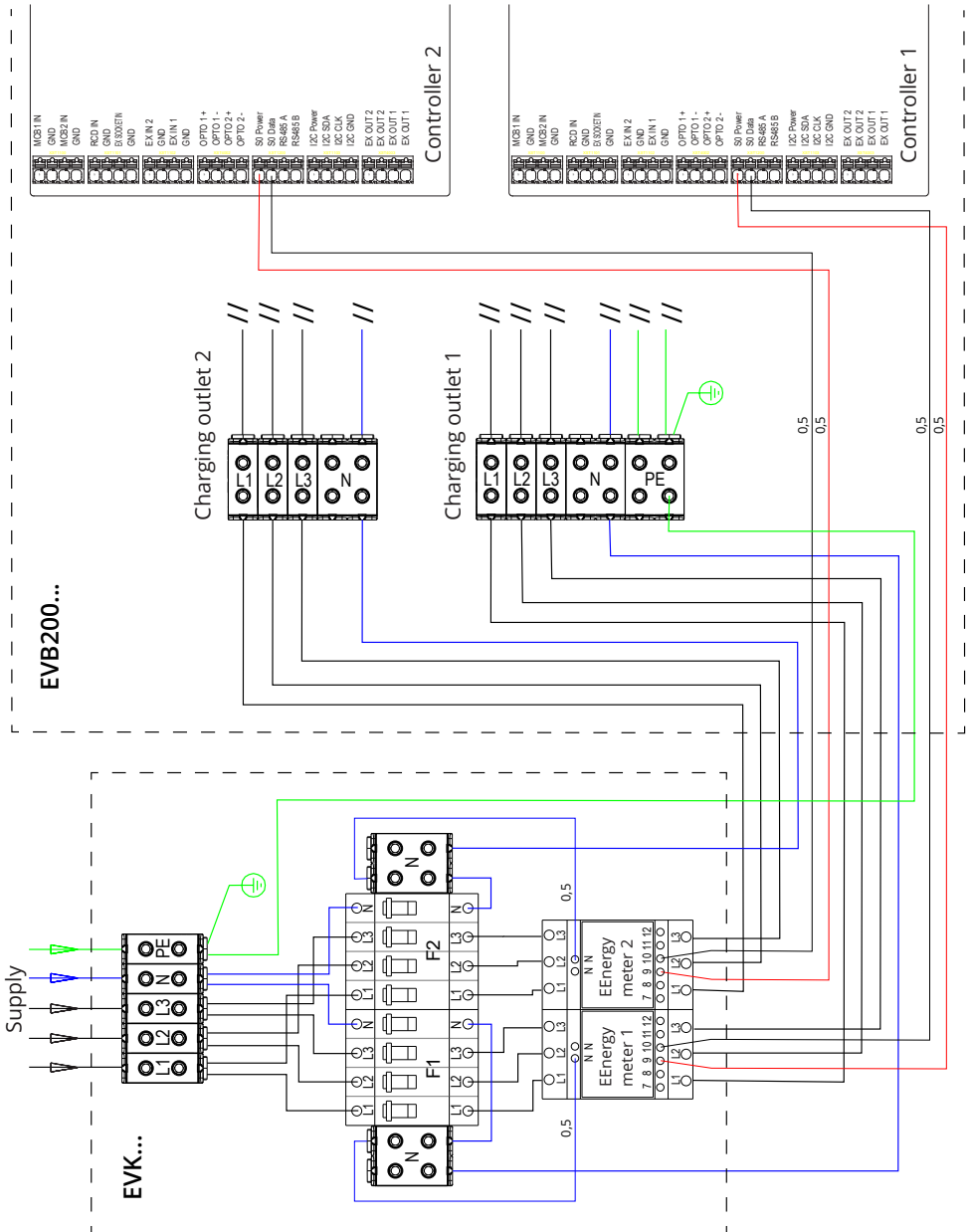

17.3. Technical Information - EVK...

Electrical Connections and Components	
Nominal supply voltage	1-ph/3-ph, 230/400VAC, 50Hz
Supply connections and terminals	L1, L2, L3, N, PE Cu 2.5-50 mm ² Tightening torque: 4 Nm (2.5 - 4 mm ²), 12 Nm (6 - 50 mm ²)
RCB / MCB	Type A 30mA, class C, nominal current 32A
Energy measurement	MID class energy meter

Design and Mechanics	
Materials	Polycarbonate
Color	Frame: grey RAL7035 Cover: transparent
Dimensions	300 x 400 x 132 mm
Weight	approx. 4,1 kg, depends on product configuration
Enclosure class	IP66
Shock protection rate	IK08
Operating temperature	-25 °C ... +65 °C
Mounting	On wall with fastening lugs

18. Troubleshooting

Charging station is off, no lights on

Issue	Corrective action
Mains voltage does not exist in supply connector L1.	Ensure proper power supply.
Circuit breaker F0 is off.	Turn F0 on.
12V power unit has no LED on.	Ensure 230V power supply to 12V power unit; if ok replace the power unit.
The controller has no PWR LED on.	Ensure power supply to the controller; if ok replace the controller.

Charging cable is locked in Mode 3 socket outlet

Issue	Corrective action
Unexpected fault has occurred while power is on.	Option 1: If equipped with Mode 3 lock release functionality, turn off the power from F0 and pull charging cable out from the socket. Option 2: Turn off the power. Switch Mode 3 lock manually into open position.
Power is off.	Open the front cover. Switch Mode 3 lock into open position. Note! If the station has a Mode 3 Lock Release functionality, then during power cut the Mode 3 lock opens automatically.

Configuration via web browser

Issue	Corrective action
PC does not recognize micro USB plug and connection to the controller cannot be established via web browser.	Check from Windows 7 / 10 operating system settings via "Device Manager" that RNDIS network adapter is available. If not, update the related Windows driver.

19. Warranty

Warranty conditions, see the product card on www.ensto.com.

Better life.
With electricity.



ENSTO

Ensto Finland Oy
Ensio Miettisen katu 2, P.O. Box 77
FIN-06101 Porvoo, Finland
Tel. +358 20 47 621
Customer service +358 200 29 007
ensto@ensto.com

